



Winlet 375

Maximum capacity - minimum space

Winlet 375 combines superior lifting capacity and reach with a unique and compact design.

With Winlet 375, you can handle heavy elements up to 375 kg bringing them through rough terrain and narrow doorways.

Due to the compact design, confined spaces such as elevators and balconies are no problem for Winlet 375.

Low weight

The low weight of Winlet 375 makes it possible to use it where heavier construction equipment cannot be used due to surface pressure.



Winlet 375



WINLET 375 MAX. LOAD kg.

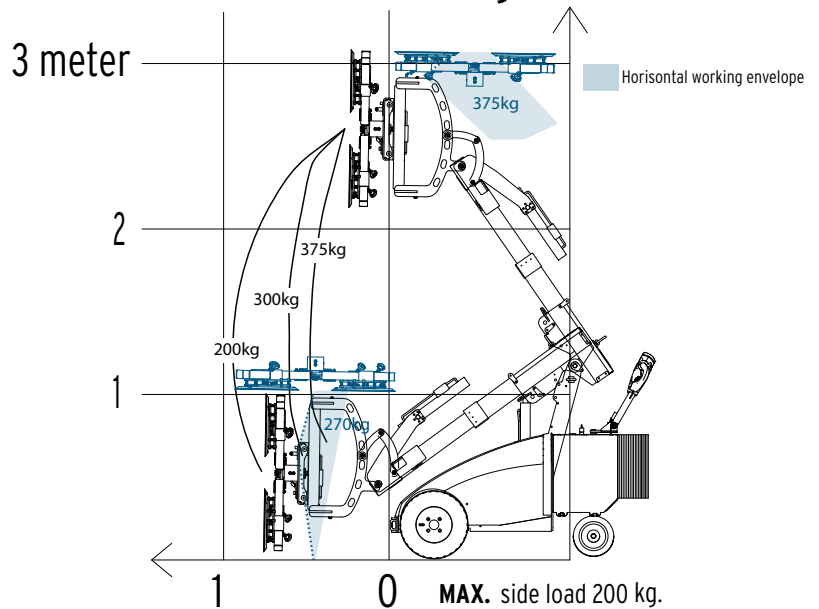

SPECIFICATIONS*

EXTERNAL LENGTH	1.545 MM	HYDRAULIC FINE LIFT ON ARM	200 MM
WIDTH - Single mounted tires	690 MM	TILT FUNCTION OF FRONT - Horizontal arm	BACK: 45° FORTH: 97°
WIDTH - Twin mounted tires	920 MM	ROTATION	ENDLESS
TOTAL WEIGHT - Excl. Counterweights	578 KG	SUCTION CUPS	4 X Ø310 MM (Ø360/Ø410 MM)**
TOTAL WEIGHT - Incl. Counterweights	732 KG	FRONT WHEEL DRIVE - 24v AC transaxle	1200W
MAX LOAD ARM IN/OUT	375 KG/ 200 KG	MAX SPEED	0-5 KPH
MAX SIDE MOUNTED LOAD	200 KG	BATTERIES	2 X 90 AH
EXTENSION MIN/MAX - Front bumper to suction cup	487 MM / 958 MM	OPERATING HOURS- On fully charged batteries	12 HOURS
LIFTING HEIGHT MIN/MAX - Horizontal cups down	0 MM / 890 MM	SUITABLE FOR OUTDOOR USE- Water resistant	YES
LIFTING HEIGHT MIN/MAX- Horizontal cups up	2.670 MM / 3.078 MM	INTEGRATED LIFTING EYE- For lifting of the Winlet	YES
MANUAL SIDE SHIFT	100 MM		

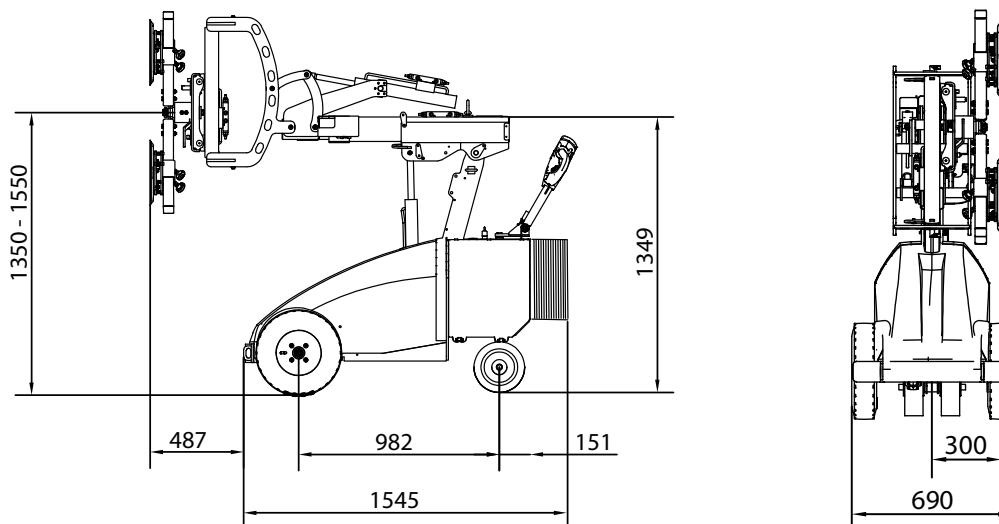

*The dimensions are indicative and may vary +/- 10mm. The photographs and/or drawings in this document are for illustrative purposes only.

**Optional