

ATN

NEW

PIAF 1010

Mast boom lift PIAF
1010



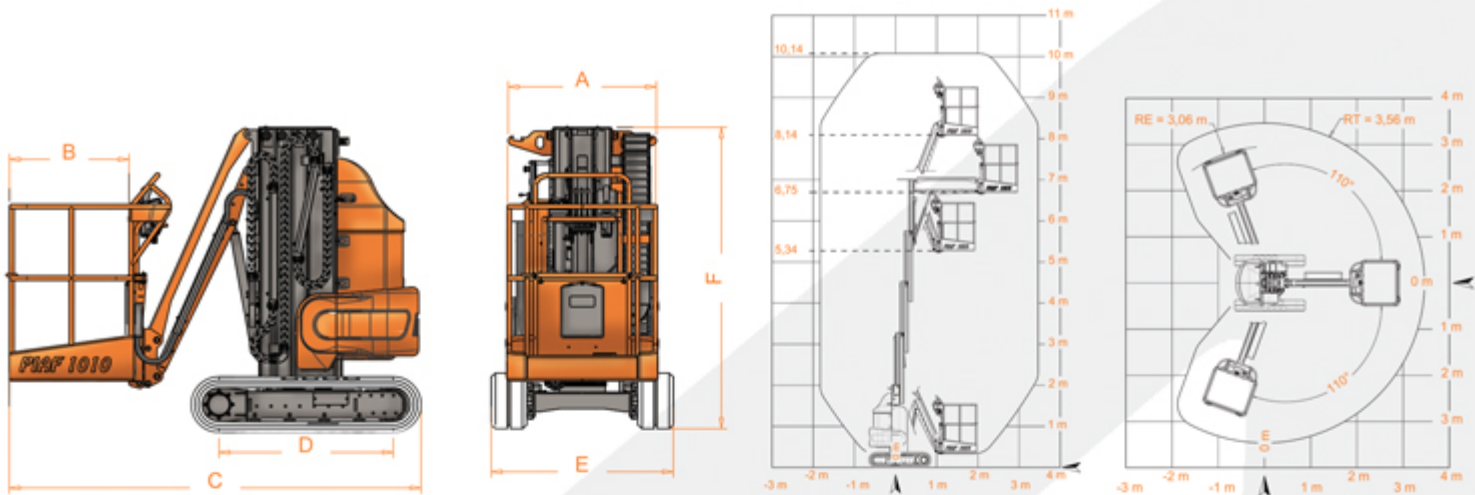

PIAF 1010 Tracks

ADVANTAGES

- Efficiency thanks to the 2 x 110° rotation of the top.
- Designed for any indoor or outdoor job site.
- Smooth operating thanks to the hydraulic joystick.
- Easy to operate.
- Zero turning radius.
- Preserving fragile floors.
- Designed and manufactured for heavy-duty use.

STANDARD FEATURES

- Non-marking rubber tracks.
- Progressive hydraulic joystick transmission.
- Driving operated by a hydraulic joystick.
- 560 Ah 24 V centralized battery filling system.
- 85 A battery charger.
- 2 drive speeds.
- Lifting facilities.
- Emergency hand-pump.
- Battery indicator with 80% discharge cut-off.
- Tilt indicator with buzzer.
- Overload sensor.
- System preventing from tipping over.
- Hour meter.
- Strong large size platform.

OPTIONS

- Air line to platform.
- 220V AC power to platform.
- Automatic power cut-off if tilt value >3°.
- Flashing light.
- Motion alarm.
- Special paint colour(s).

	PIAF 1010
Working height	10,05 m (32 ft. 9.7 in.)
Platform height	8,05 m (26 ft. 4.1 in.)
Horizontal reach	3,35 m (10 ft. 9.9 in.)
Lift capacity	200 Kg (440 lbs.)
Turntable rotation	2 x 110 ° (2 x 110 °)
A Platform width	0,90 m (2 ft. 9.5 in.)
B Platform length	0,80 m (2 ft. 6.2 in.)
D Wheelbase	1,20 m (3 ft. 9.3 in.)
E Width	1,20 m (3 ft. 9.3 in.)
C Length- stowed	2,70 m (8 ft 8.6 in.)
F Height - stowed	2,12 m (6 ft. 9.5 in.)
Drive speed - stowed	1,6 Km/h (1 Mph)
Drive speed - raised	0,9 Km/h (0.55 Mph)
Turning radius	0 (0)
Gradeability - stowed	30 % (30 %)
Maximum tilt value	3 ° (3 °)
Weight	2780 Kg (6129 lbs.)
Max.ground bearing pressure	69 kN/m ²

CE This product complies with European regulations in force (EN 280). Due to our constant improvement policy, ATN reserves the right to make any modifications without any prior notice.



Rue André Thevet,
Z.I.Guillaume Mon Amy Fauillet 47400 FRANCE
+33 (0) 553 798 320 +33 (0) 553 880 107
<http://www.atnplatforms.com>

