



PANORAMIC P60.10

PANORAMIC P72.10



PERFORMANCE AND FEATURES	P60.10	P72.10	
PERFORMANCE			
Total unladen weight (kg)	10000	10850	
Maximum capacity (kg)	6000	7200	
Lifting height (m)	9,5	9,4	
Maximum reach (m)	5,3	5,2	
Maximum operating height (m)	7,2	6	
Maximum operating reach (m)	1,5	1,5	
Capacity at maximum height (kg)	3000	4000	
Capacity at maximum reach (kg)	1500	2000	
Lateral boom movement (mm)	+/- 250	+/- 250	
Tilting correction (%)	+/- 10	+/- 10	
Boom sections	2	2	
POWERTRAIN			
Turbo motor	Deutz TCD3.6	Deutz TCD3.6	
Displacement/cylinders	3600/4	3600/4	
Engine Power (kW/HP)	75/102	75/102	
Anti-pollution technology	EURO IV, SCR+DOC	EURO IV, SCR+DOC	
Reversible fan	-	-	
Maximum speed (km/h)	40	40	
Fuel tank (l)	140	140	
AdBlue tank (l)	18	18	
Hydrostatic transmission	● - 2V	● - 2V	
EPD	●	●	
Axles	Portal	Portal	
Reduction hub	RR640	RR640	
Machine brakes	Dry disc	Dry disc	
Automatic parking brake	●	●	
HYDRAULIC			
Hydraulic pump	Load Sensing	Load Sensing	
Flow rate/pressure (l/min – bar)	108 - 240	108 - 240	
Hydraulic tank	105	105	
Hydraulic outlet at the top of the boom	●	●	
Rear hydraulic outlets	○	○	
CAB			
Cab configuration	2004 Cab	2004 Cab	
MCDC	Full	Full	
FOPS LIV II cab	●	●	
ROPS cab	●	●	
Cab commands	Electromechanic joystick	Electromechanic joystick	
Tilting Cab	-	-	
Reverse shuttle	Finger touch	Finger touch	
CONFIGURATION			
Cab suspension	-	-	
Boom suspension	-	-	
Suspension on axles	○	-	
Work headlights on cab	○	○	
Sun blind	○	○	
Tac-lock	●	●	
Provision for a platform	○	○	
Two floating forks	●	●	
Inching-Control	●	●	
Four-wheel drive	●	●	
Four-wheel steering	●	●	
Three steering modes	●	●	
Standard tyres	18-19.5"	405/70-20	
Optional tyres	445/65-R22.5"	445/65-R22.5"	
Stabilisers	-	-	
Turret rotation	-	-	
Type approval as an agricultural tractor	-	-	
Approval with PNEUMATIC braking	-	-	
Approval with HYDRAULIC braking	-	-	
PTO	-	-	
3-point linkage	-	-	
DIMENSION			
Width (mm)	2330	2330	
Height (mm)	2440	2440	
Length (mm)	5345	5345	
Wheelbase (mm)	2875	2875	

LOAD CHARTS

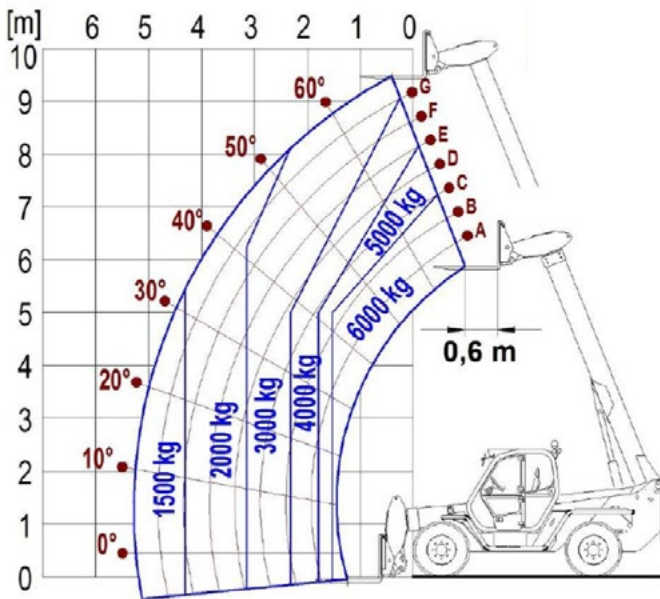

P60.10

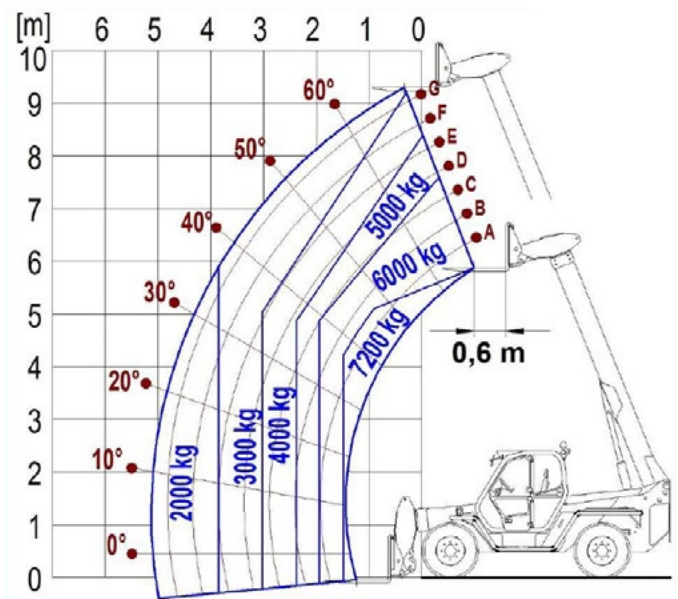

P72.10

GLOSSAR

SCR

Selective Catalyst Reduction, solution used for the reduction of NOx in the exhaust gases through the injection of a liquid - UREA (AdBlue) - into the exhaust gases.

DPF

Diesel Particulate Filter, a solution used to reduce fine particle emissions in exhaust gases

DOC

Diesel Oxidation Catalyst, a solution used to reduce carbon monoxide (CO) and hydrocarbons in exhaust gases

EGR

Exhaust Gas Recirculation, a solution used to reduce NOx in exhaust gases by recirculating gas inside the combustion chamber of the engine.

1-2V

1 or 2 speed **Merlo gearbox**

CVTronic

Continuous variation Merlo gearbox, for constant acceleration without loss of torque

EPD

Eco Power Drive, Merlo electronically-controlled hydrostatic transmission Electronic, enables effective RPM management in order to reduce overall fuel consumption by the machine

EPD Plus

In addition to the **EPD** Control, it is also possible to work using Speed Control (maintaining a constant travel speed) and Heavy Load (management of RPM in order to maximise performance for tasks such as: bucketing operations, heavy duty unloading, etc.)

EPD Top

In addition to the **EPD Plus** control function, this enables the RPM to be managed directly using the joystick

Gear

Fixed displacement pump with gears, combined with an open centre hydraulic distributor

LS

Variable displacement pump with **Load Sensing** control, combined with a closed centre hydraulic distributor

LS+FS

Variable displacement pump with **Load Sensing** control, combined with a closed centre hydraulic distributor equipped with solenoid valves and **Flow Sharing** control.

Kabine ECO/PREMIUM

MODULAR type cabin with simplified or PREMIUM equipment

MCDC

Merlo Dynamic Load Control, electronic control of the machine's anti-overflow system.

• **Light**: Simplified version; • **Complete**: Version with display in cab.

FOPS

Falling object protective structure, the system which shields the operator from heavy objects falling onto the cab. Two levels: • **FOPS Liv I**: Object with a weight of 45 kg falling from 3 metres • **FOPS Liv II**: Object with a weight of 227 kg falling from 5.2 metres

ROPS

Roll-over protection system (or roll-over protection structure), the system that protects the operator if the vehicle rolls over

Finger Touch

Driving direction inversion system mounted on the steering column

Dual Reverse

Dual driving direction inversion system, on both the steering column and the joystick

Tac-lock

Hydraulic attachment clamping system controlled from the cab



MERLO S.P.A.

Via Nazionale, 9
12010 S. Defendente di Cervasca
(Cuneo) Italia

Tel. +39 0171 614111

Fax +39 0171 684101

info@merlo.com

www.merlo.com



DS_P60P72_1117_XG